

NEW 2'x2'x1' FOOTING
REINFORCED W/3-#4 BARS
E.W. BOTTOM.- TYP

NEW 6x6 P.T.
POST- TYP.

FIRST FLOOR FRAMING

SCALE: $\frac{1}{8}'' = 1'-0''$

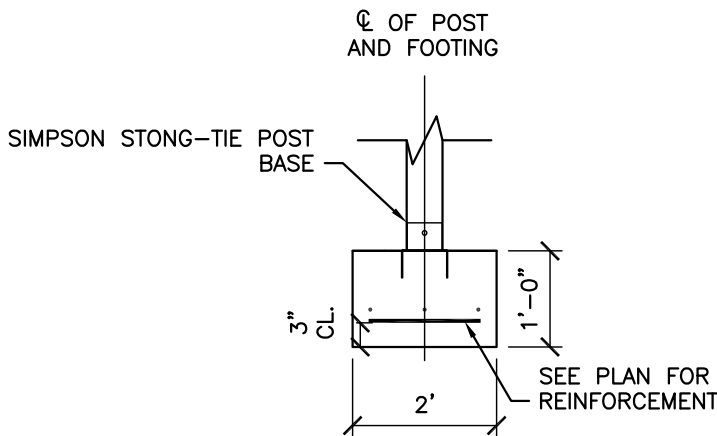
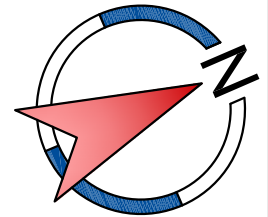

TYPICAL ISOLATED FOOTING

SCALE: $\frac{1}{2}'' = 1'-0''$

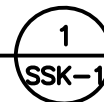

Civil & Structural Engineers
DeWolfe
 ENGINEERING ASSOCIATES
 PROFESSIONAL CORPORATION
 317 River St., P.O. Box 1576, Montpelier, VT 05601-1576
 t. 802-223-4727 f. 802-223-4740 www.dirtsteel.com

project name: 375 Sharkyville Rd, Bolton
 project number: 21206
 drawing reference: SSK-1
 scale: $\frac{1}{8}'' = 1'$
 date: 02 AUGUST, 2021
 revision number: Δ
 revision description:

sheet description:
 FLOOR FRAMING
 PLAN

SSK-1